

THIS DRAWING IS UNPUBLISHED. RELEASED FOR PUBLICATION  
 © COPYRIGHT - By - ALL RIGHTS RESERVED.

LOC		DIST		REVISIONS			
P	LTR	DESCRIPTION		DATE	DWN	APVD	
	T	REV PER ECO 15-000491		4-24-15	CT	CD	

1. THIS PART CONFORMS TO REQUIREMENTS FOR DANIELS CRIMP TOOL NO. M300-BT, WITH DANIELS POSITIONER PART NO. SP689, STRIP LENGTH .375, #8 AWG SETTING 7, #10 AWG SETTING 3.
2. MATES WITH 211161-1 IN AMPLIMITE CONNECTOR ASSEMBLIES ONLY.
3. FINISH: PLATED GOLD .000050 [0.00127] MIN THK PER ASTM-B-488 OVER NICKEL .000050 [0.00127] MIN THK PER QQ-N-290.
4. FINISH: PLATED GOLD .000030 [0.00076] MIN THK PER ASTM-B-488 OVER NICKEL .000050 [0.00127] MIN THK PER QQ-N-290.
5. NOT FOR GENERAL DISTRIBUTION; USAGE RESTRICTED TO SPECIFIC CUSTOMER CONFIGURATION.
6. RESTRICTED PART NUMBER.
7. FINISH:  
MATING AREA: GOLD PER ASTM-B-488 (TYPE II) OVER NICKEL PER AMS-QQ-N-290  
NON-MATING AREA: GOLD STRIKE PER ASTM-B-488 OVER NICKEL PER AMS-QQ-N-290
8. DIMENSION MUST BE MEASURED USING A RING GAGE.

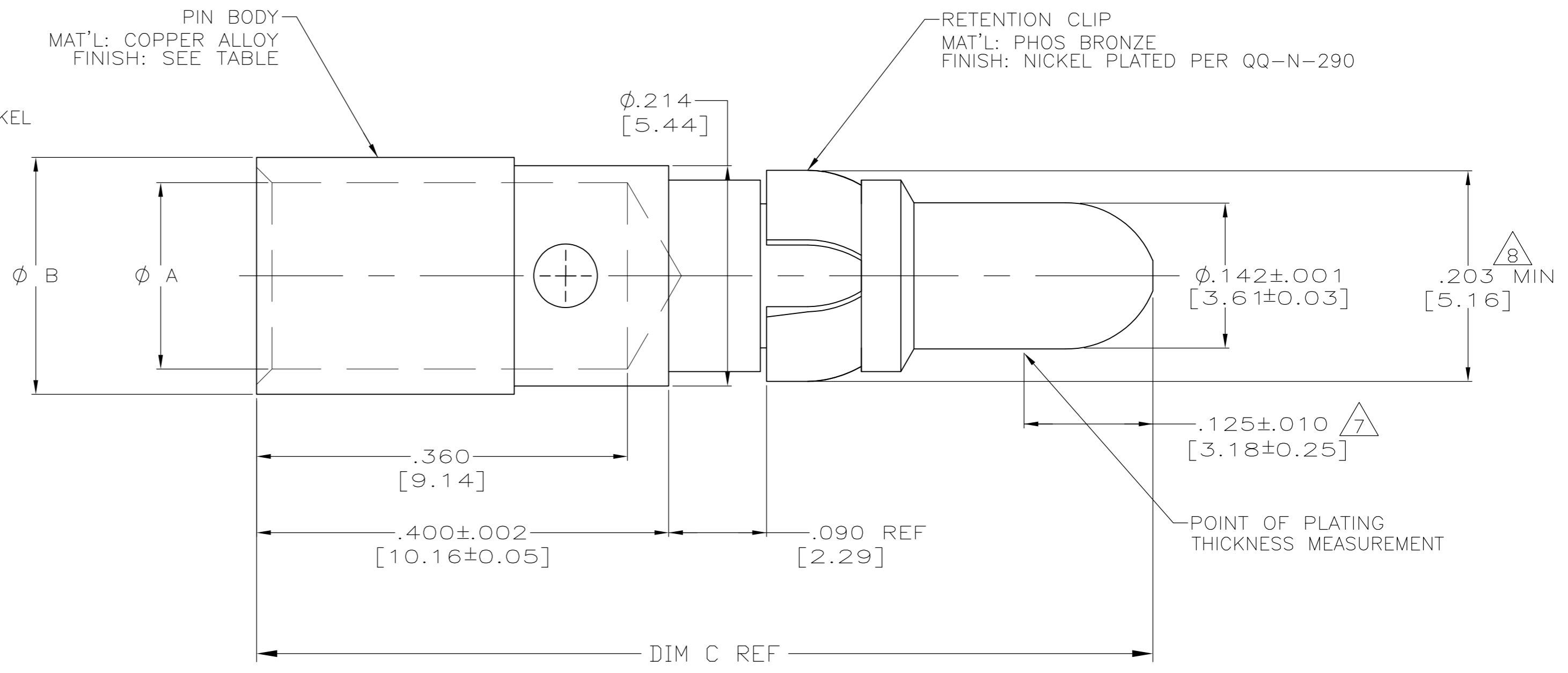

REMARKS	FINISH	DIM C	DIM B	DIM A	WIRE SIZE	PART NUMBER
						1-211159-2
						1-211159-1
PRELIMINARY- NOT RELEASED FOR PRODUCTION	3	.948 [24.08]	.230 [5.84]	.181 [4.60]	#8 AWG	211159-5
PRELIMINARY- NOT RELEASED FOR PRODUCTION	4	.870 [22.10]	.185 [4.70]	.136 [3.45]	#10 AWG	211159-4
PRELIMINARY- NOT RELEASED FOR PRODUCTION	4	.870 [22.10]	.230 [5.84]	.181 [4.60]	#8 AWG	211159-3
	7	.870 [22.10]	.185 [4.70]	.136 [3.45]	#10 AWG	211159-2
	7	.870 [22.10]	.230 [5.84]	.181 [4.60]	#8 AWG	211159-1

THIS DRAWING IS A CONTROLLED DOCUMENT.

DWN	C.C.THOMAS	11/10/00
CHK	D.MILLER	11/10/00
APVD	D.MILLER	11/10/00

TE Connectivity

ASSEMBLY, PIN CONTACT  
POWER VIII, #8 & #10 AWG

SIZE	A2	CAGE CODE	00779	DRAWING NO	211159	RESTRICTED TO	-
SCALE	10:1	SHEET	1 of 1	REV	T		

CUSTOMER DRAWING